

INSTRUCTION MANUAL

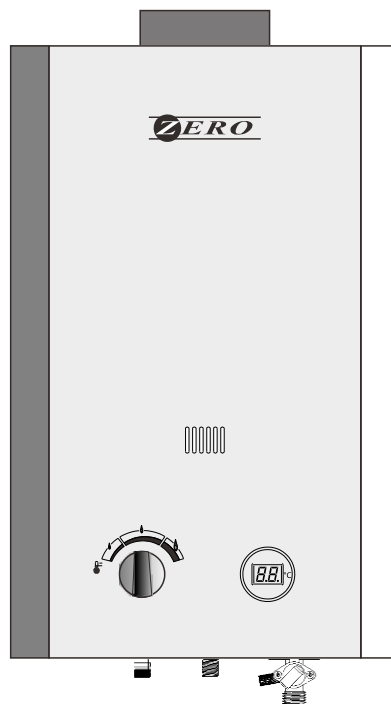

ZERO START HOUSEHOLD INSTANT GAS WATER HEATER

With NEW Water Flow Sensor for Low Pressure Start.



CERTIFIED TO ISO9001
INDOOR & OUTDOOR USE

**PLEASE READ THIS MANUAL CAREFULLY
PRIOR TO USE AND INSTALLATION**

RETAIN THESE INSTRUCTIONS FOR FUTURE REFERENCE.
TO BE INSTALLED BY A LICENSED GAS PRACTITIONER ONLY.

Before using, please carefully read the manual; make sure you understand the safety notices and the correct way of installation.

(1) BASIC TECHNICAL DATA

B AND NAME		ZE 0			
VOLUME		8LIT E	12LIT E	16LIT E	E
MODEL NUMBE		JSD16-LN2	JSD24-LN2		
GAS TYPE		Liq i P t l			
ATED GAS P ESSU E		2 8kP	2 8kP		2 8kP
WATE P ESSU E EQUESTED	STA		0 0IM		0
	OP E ATING FLOW				600L/H
	EQU I ED				960L/H
CONSUMPTTON AT MAX					3 75kg/h
		tt i			
		i			
		i			
				f t	
		i bigg 15mm			

TO BE FITTED WITH SANS1237 APPROVED REGULATOR WITH A MINIMUM DELIVERY CAPACITY OF 3KG.

REMARK: Gas type and rated gas pressure should be according to the nameplate on the water heater's body.

As to other technical data, please refer to individual model's performance sheets respectively.

ALSO REFER TO THE GAS PIPING SIZES IN SANS10087-1.

INSTALLATION:

THIS APPLIANCE MUST BE INSTALLED IN ACCORDANCE WITH I.A.W. AND SANS 10087 PART 1.

IT MUST ONLY BE INSTALLED BY A CERTIFIED LPGSA INSTALLER.

2) FOR YOUR SAFETY

THIS APPLIANCE IS SET TO OPERATE ON LPG ONLY

IF YOU SMELL GAS:

- Turn off the gas supply at the bottle
- Extinguish all naked flames
- Do not operate any electrical appliances
- Ventilate the area
- Check for leaks as detailed in this manual

IF THE ODOUR PERSISTS, CONTACT YOUR LOCAL DEALER OR GAS SUPPLIER IMMEDIATELY

BURN-BACK (FIRE IN BURNER TUBE OR CHAMBER)

In the event of a burn-back (where the flame burns back to jet) immediately turn off the gas supply at the control valve on the panel. After ensuring that the flame is extinguished, re-light the appliance in the normal manner. Should the appliance burn back again, close the control valve and call a service technician. Do not use the appliance again until the service technician has declared that it is safe to do so.

GAS PRESSURE REGULATOR

This appliance requires an operating pressure of 2,8 kPa at the appliance. A suitable LPG regulator that complies with the requirements of SANS 1237 must in installed.

IMPORTANT INFORMATION FOR THE USER

This appliance may only be installed by a registered and certified LP gas installer. All registered installers are issued with a card showing their registration number. Ask to be shown the card before allowing the installation work to commence and make a note of the Installer QCC number. Upon

completion of the installation, the installer is required to explain the operation details of the appliance, together with the safety instructions. You will be asked to sign acceptance of the installation and be provided with a completion certificate. You should only sign for acceptance of the installation when the installation is completed to your satisfaction. Note that your invoice is required in the event that you wish to make a guarantee claim.

IMPORTANT INFORMATION FOR THE INSTALLER

This appliance may only be installed by an LP gas installer, registered with the Liquefied Petroleum Gas Association of Southern Africa. The appliance must be installed in accordance with the requirements of SANS 10087-1 and any fire department regulation and /or local by laws applicable to the area. If in doubt, check with the relevant authority before undertaking the installation. Upon completion of the installation, you are required to fully explain and demonstrate to the user the operational details and safety practices applicable to the appliance and the installation.

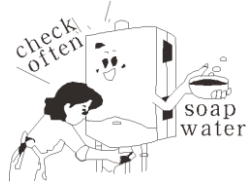

Check fittings and connections regularly with a 50/50% soap water solution for gas leaks.

Spray or brush the soapy water solution on all joints. If any bubbles form around the connection, tighten the joints. If the leak persists, stop using the geyser, close the cylinder valve at the cylinder, remove the batteries that can be a possible ignition source and contact your installer or local qualified gas dealer.



Do not use your gas geyser for any other purpose except for producing hot water, i.e do not use for drying clothes, thus blocking the air vents.

Always drain the water at the water exhaust if the geyser was not in use for some time, or if the temperatures drop below 0°C.

REPAIR

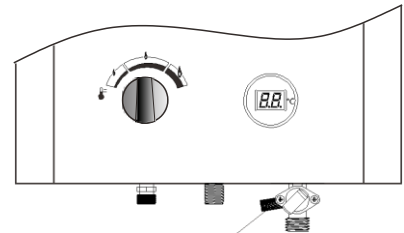

Water exhaust valve

In no circumstances may an unauthorized person tamper with this unit. Only authorised, LPGSA certified persons may carry out any repairs on your geyser. For anyone else to do so is not only extremely dangerous, but it is against the law!! (See *D.O.L., P.E.R. and SANS 347)

(* Dept of Labour, Pressure Equipment Regulations, South African National Standard)

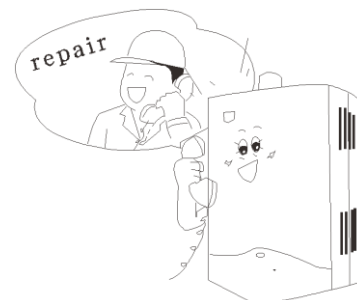

● THE CORRECT POSITION IN THE INSTALLATION ROOM

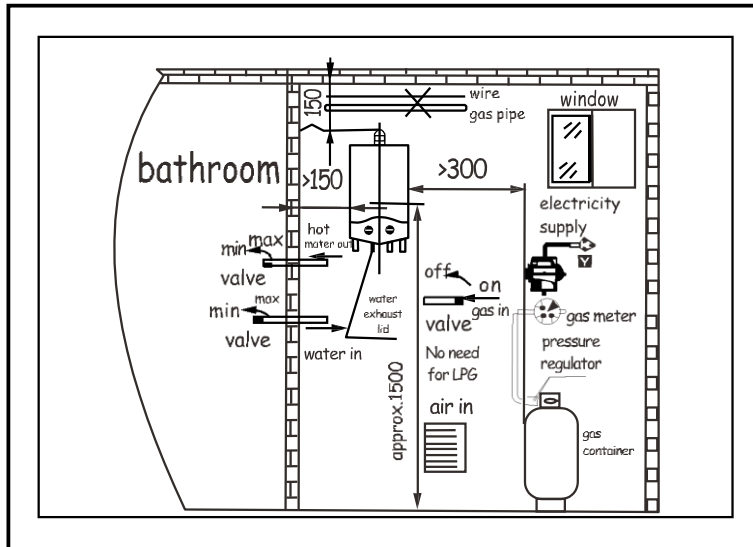

Notes:

If flexible hose being used, it MUST be BS3212 or SANS1156 approved hose. The hose MUST NOT be longer than 2 metres.

The hose should NOT be fed directly through a wall or cupboard, neither should it be behind or above the geyser.

We DO NOT recommend using hose for the gas connection. This will restrict the gas flow volume and will have under performance as result. We recommend to use 15mm. copper/composite or stainless steel flex pipe.

● The installation of the hanger should be in a horizontal position.

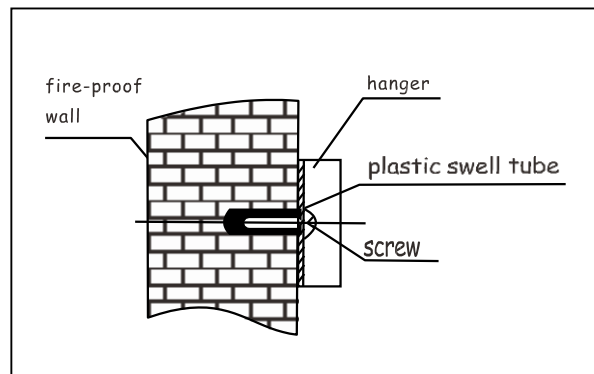
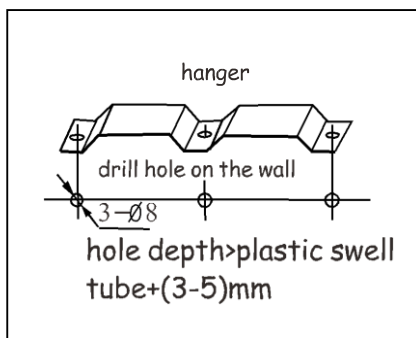

In case of non fire-proof wall, please underlay a fire-proof board, 100mm bigger than the water heater from every side and 10mm away from the wall.

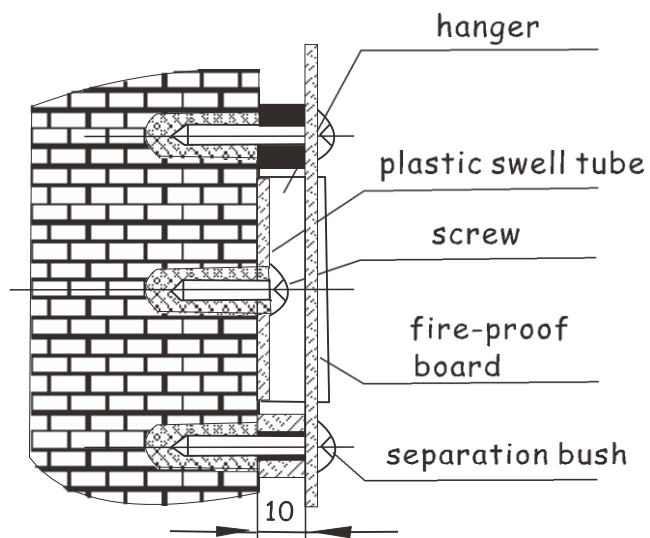

HANG UP THE WATER HEATER
Hang up the water heater onto the hanger vertically

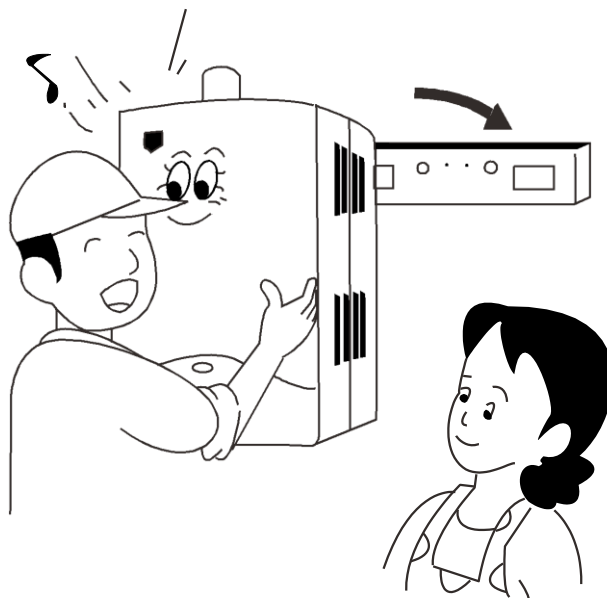

IMPORTANT: Please install the geysers under an overhang if you want to install the geysers outside. The unit may rust inside if you don't follow instructions and leave the unit exposed in the rain with no protection.

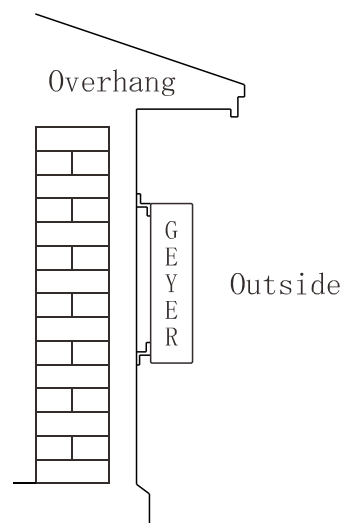

● INSTALLATION OF FLUE

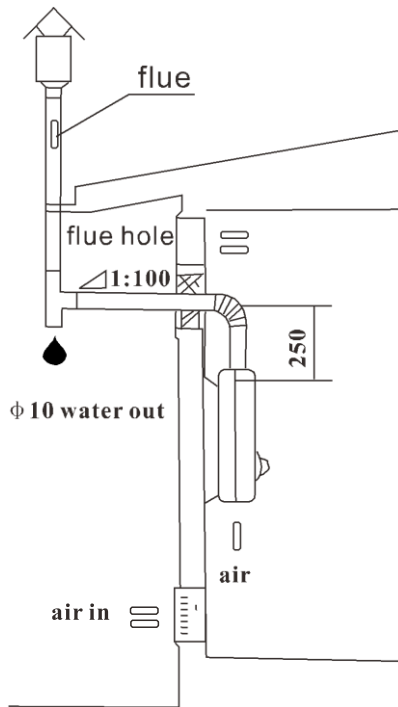

The water heater must have a flue. Flue installation should be as following:

- A. The flue should be properly sealed to ensure that NO exhaust fumes leak to the inside of the house.
- B. The horizontal part of the flue should be less than 3m, and the vent should be inclined down a little so that the condensated water or rain could not flow backwards.
- C. Elbow of the flue should be 90° and not more than 3pcs.
- D. The distance of the section above the flue diverter of the geyser, before venting to the outside, should not be less than 250mm.
- E. The top of the flue must have a top cover to deflect the wind and prevent rain, snow and other debris entering the flue, blocking the geyser inside passage way.
- F. Secure the flue when it is exposed in windy areas or extreme draught conditions.
- G. Make sure that there is no air/fume leakage at the flue joints. Use self tapping screws or pop rivets secure the sections.
- H. If the outside upright flue is 2 metres then the horizontal distance should be no more than 50% of that distance, i.e if the flue is 2 metres, then the horizontal at the bend SHALL not be over 1 metre)

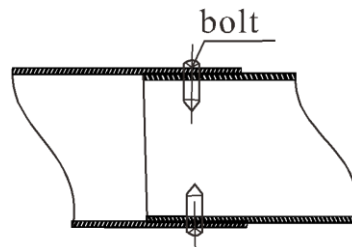

● HOW TO SET UP THE AIR VENT

- A. The air vent should be as near to the floor as possible, but below the halfway distance of the total distance to the ceiling.
- B. The exhaust flue should be to the outside of the room and properly sealed to prevent exhaust fumes entering to the inside.
- C. The bend to the outside shall not be less than 250mm from the centre of the flue to the geyser connection.

D. The air entry and vent area requirements. (See table below.)

THERMAL BURDEN (KW)	MIN. AREA OF THE AIR-IN HOLE AND VENT HOLE(CM ²)
≤12	100
12~16	130
16~20	160
20~26	200

● **Installation :**

1. Gas inlet.

Use two wrenches. (IT WILL BREAK IF NOT HELD WITH ONE WRENCH at geyser outlet!) Use swivel fitting as supplied.

2. Hot water outlet.

It is recommended to fit FULL BORE water valve. Do not use Flex type toilet connectors. The flow will be restricted.

3. Cold water inlet.

Flush the cold water pipe before connecting to free of dirt. When using water from STORAGE tank, it is recommended to fit inline water filter.

Do not use Flex type toilet connectors.

WARNING:

You need a balanced water system to ensure that the water pressure will not drop in opening cold water taps. This is a half inch hot water outlet and it cannot be increased to a three quarter inch hot water system.

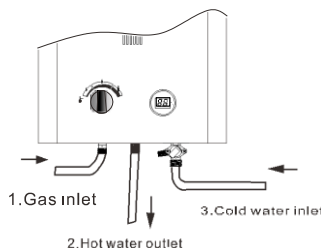

● **PREPARATION:**

The geyser ignition function is powered by two large 1.5V. DC (Type D) torch batteries. Please insert the correct way as indicated on the battery housing. Batteries not included.

IGNITION:

Switch on the geyser at the on/off switch that can be found on the bottom of the front cover between the cold water inlet and hot water outlet (please switch the unit off in long periods of no use)

Open the warm water tap. The electronic igniters will light up the main burners after 6 to 10 seconds.

First time ignition after installation, or when changing the cylinder, might take a bit longer as there will be air inside the gas pipe. Repeat if ignition is not obtained within the first 10 seconds. **REMEMBER THAT THE INSTALLER MUST BY LAW COMMISSION YOUR NEWLY INSTALLED WATER GEYSER IN YOUR-OR YOUR REPRESENTATIVE-PRESENCE BEFORE SIGNING OFF THE INSTALLATION.**

● **PRECAUTIONS.**

As a precaution, if you are away from home and the geyser will not be in use for a time, **CLOSE THE CYLINDER VALVE.**

Always close the cylinder valve first before changing the empty cylinder with a full cylinder.

● **TEMPERATURE CONTROL**

For higher temperature, turn more gas and less water

For lower temperature, turn less gas and more water

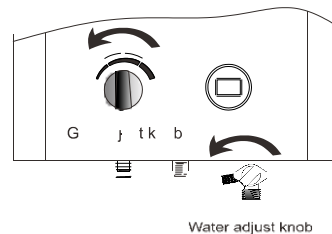
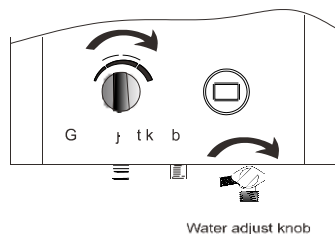

To adjust:

Use the clearly marked controls on the Geyser.

You can adjust the flame from low to high as well as the required water flow. If the water flow is too high, close the valve at the cold water inlet slightly.

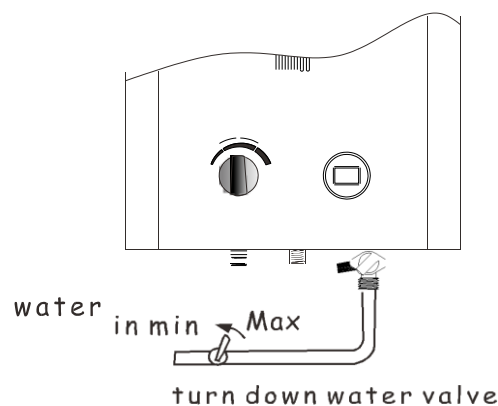

● **SHUT-OFF**

The geyser will shut-off automatically when you close the warm water tap. It will also shut-off if you close the cold water inlet tap to the geyser, or if you close the cylinder valve.

This geyser must not be used for anything other than for the heating of water.

- **NOTE:**the heater should **not be** used continuously for periods longer than **20 minutes at a time.**

● **TROUBLE-SHOOTING**

PROTECTIVE FUNCTION	REACTION	REMARKS
Water pressure too high	If water pressure is over 0.8Mpa, the water-out valve will release water and lower the pressure	Increase the valve pressure limit according to local water supply pressure
20-minute automatically shut off	After 20 minutes' using, water heater will shut off automatically	Restart the water heater
Water pressure too low Fit water pressure pump to boost pressure.	If water pressure is below 0.025Mpa the water heater cannot be ignited	Use the water heater later when pressure becomes higher
Low battery	Although a spark noise can be heard, the battery power is too low to open the solenoid valve.	Change battery
Over heat protection	Water heater automatically shuts off when water temperature is above 77°C	Re-start water heater later when water becomes cooler

■ **Repair and Maintenance**

- Water heater shall be checked by a professional person,

every 6 to 12 months. The following must be checked:

1. For leaks on the gas connections. (do leak test as page 2.)
2. For leakage on water in and outlet.
3. Check that the water inlet sieve is free from dirt and clogging.
4. That all parts function 100%.

5. Flame quality and combustion. (Soot)
6. Carbon accumulation on heat exchanger.
7. Check that there is no combustion leaking to the inside of the room.
8. Gas regulator.

● Items check and maintained by professional personnel.

1. Clean water inlet from blockage.
2. Clean carbon build-up on heat exchanger.
3. Grease the core of the water section to gas section.
4. Clean carbon accumulation and oxidation on igniters. (ceramic sparkers.)

● Owner maintenance.

1. Clean outside cover with warm water and dishwashing liquid, using a soft cloth.

Do not use abrasive cleaners or scourers.

2. Clean cover vents with a soft brush.

3. Check the flue. make sure there is no obstruction. After cleaning, make sure that the flue is properly fitted so NO combustion will be released to the inside of house.

Make sure that no dirt be dropped to the inside of the geyser.

Note: Removing vent-pipe, clean it and rid up heat exchanger with brush. During the course, do not drop dirt an dusts into fire hole of burner and parts of electric appliance and do not loosen or damage othe parts as well. to re-fix the vent-pipe after cleaning, notice to keep tight sealing of joints.

■ Maintenance and repair guide to common malfunctions

Cause		Malfunction	A	B	C	D	E	F	G	H	I	J	Solutions	
Imp p Op t		Gas flow	●										Gas flow	
		Water supply	●										Water supply	
		Improper installation method of water meter				●							Enlarge gas flow	
		Improper position of water switch	●				●						Reduce gas volume, enlarge water supply	
S d		Air leakage	●	●									Reduce air leakage	
		Inadequate fresh air supply			●								Improve ventilated supply	
	Fl p	Too high	●	●			●		●				Regulate pressure relief valve, reduce overall gas supply	
		Too low			●	●				●			Check if gas rubber pipe twists or not	
	Water p	Too high				●							Reduce water supply	
		Too low	●	●	●				●	●			Utilize when water pressure recovers	
	I d q t supply of fuel gas	Gas valve is half opened				●								Open gas valve completely
		Pipe diameter too small				●								Check pipe diameter
		Water heater with a content of over 8 liters				●								Water heater with a content of over 8 liters (LPG)
		Improperly installed pressure relief valve				●								Water heater with a content of over 8 liters (LPG) of 1.2m ³ /h
		Simultaneous use by several users				●								Stop simultaneous use
		Blockage of water meter	●			●								Clean water meter on water admitting
		Blockage of shower	●			●								Clean shower device
		Blockage of vent pipe						●						Clean vent pipe
		Inadequate battery voltage	●	●	●									Replace battery
	Too low water temperature				●								Reduce water volume	
Safety p t t		Exorbitant air pressure protective device	●	●									Utilize when air pressure recovers to normal	
		Electrical leakage protective device works	●	●									Ask for professional repair	
		Heat protective switch works			●								Stop	
		20-minute timing protective device works			●								Reopen hot water valve	
	Other										●	Ask for professional repair		

1. The installer MUST use two wrenches:

- One to hold the gas inlet on the geyser and,
- One to tighten the 1/2" swivel to 15mm. copper solder. (Supplied)
- This is the correct way to install the gas inlet.
- If you use a 1/2" female to hoesetail connection with a 8mm hose, the Gas Flow Volume will be inhibited and this will increase the gas pressure.
- This geyser operates on Gas volume at 2.8 kPa ONLY and not increased pressure!

2. If installed inside, ensure that

(a) the Flue is flued to the outside.

(b) the installer abides by SANS 10087-1 specification of cross-ventilation. (i.e. a free cross sectional area of not less than 3cm²/MJ/h of heat input shall be installed, one at high, and one at low level.)

IF INSTALLED OUTSIDE, A FLUE MUST BE FITTED AS THIS UNIT IS FITTED WITH A FLUE SENSOR.

BY LAW, IT MUST CUT OUT WITHIN 4 MINUTES IF NO FLUE IS FITTED!!!!!!

BRIDGING OUT OF THE FLUE SENSOR IS NOT PERMITTED!!!!

A valid COC must accompany any warranty claim!

3. (a) Have you flushed the cold water section before connection to get rid of dirt?

(b) Have you fitted a FULL BORE shut off valve?

(c) Do not use Flex hose (toilet pipe) as this will restrict the flow!

Use 1/2" swivel connectors.

(available at DELTA ENGINEERING)

For any assistance, Contact Delta Engineering: 012-8037910/8102/8461.



Zero Appliances (Pty)Ltd
P O Box 426
Edenvale
1610
South Africa
Tel: +27 (0)10 207 1600
Fax: +27 (0)10 207 1676